

ABAR/MS2IN1

Q-Nex Plug & Play 2-In-1 Microwave And Corridor Sensor



PRODUCT FEATURES

- Easy Commissioning & Programmable Using DIP Switches
- Install In Seconds
- Maximum Mounting Height Of Up To 5m
- Maximum Detection Range Of Up To 10m
- 5 Year Guarantee
- Suitable For Use With Barracuda And Barracuda Extreme Batters

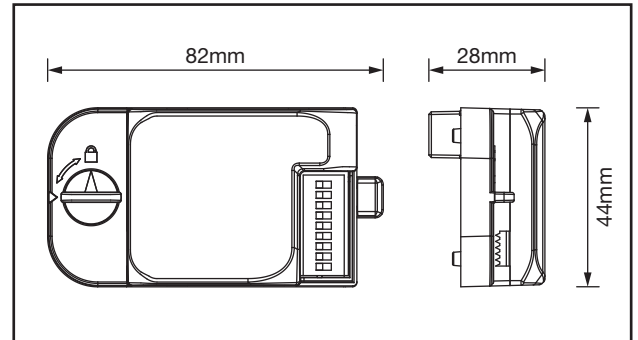
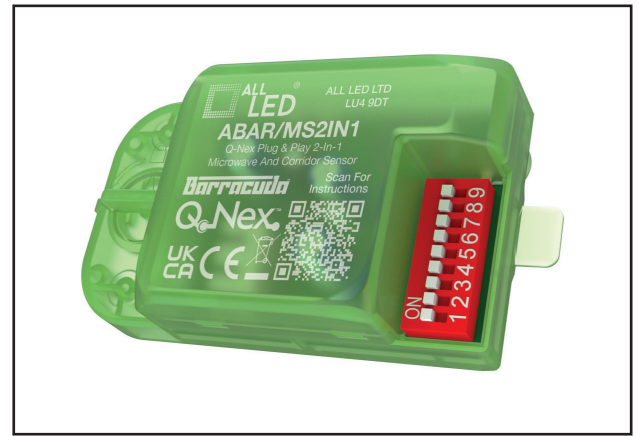

TECHNICAL SPECIFICATIONS

Code	ABAR/MS2IN1
Mounting Height	5m Max
Detection Range	10m Max
Detection Angle	120°
Standby Dim-Level	10%, 30% Or Off
Standby Time	0s, 10s, 15 Minutes Or Permanent
Hold Time	5s, 30s, 90s 1min, 3min, 5min, 10min, 20min, 30min
Sensitivity	25%, 50%, 75%, 100%
Daylight Sensor Parameters	2Lux, 10Lux, 25Lux, 50Lux Or Disable
Guarantee	5 Years
Body Material	Polymer
Frame Colour	Green
Switching Cycles	25,000
Ingress Protection	IP20
Ambient Operating Temperature (°C)	-20°C~+50°C
Lifetime	50,000 Hrs

