

KEWTECH

JAWS

Open Jaw Electrical Tester

Instruction manual



CE



kewtechcorp.com

2. Technical specifications

Model No .	JAWS
Operating current	<20mA
Standby current	<20 μ A
Press button	<p>a) Power On - Press once to power on, press > 5 secs. OFF</p> <p>b) Hold - Press once, LCD on screen blinks, another press releases</p> <p>c) Rel. - Press and hold for 3 secs.</p>
Back light	Auto ON /OFF
Auto power off	Approx. 5 mins.
Low battery indication	When <2.5V
Function switch	<p>a) 0 - 40MΩ Resistor measurement</p> <p>i) Continuity check - < 50Ω buzzer sound</p> <p>ii) Resistor- 0 - 40MΩ (approx.) > 39.95MΩ (approx.) display 'OL'</p> <p>b) 2- 200A, AC/DC current measurement: < 2.0A display 'Auto', > 219.9A display 'OL'</p> <p>c) AC / DC voltage measurement</p> <p>i) AC voltage : <0.7V display 'Auto'; > 700V alarm sound ; > 748V display 'OL'</p> <p>ii) DC voltage : <0.7V display 'Auto'; > 900V alarm sound; > 998V display 'OL'</p>
Max. Conductor diameter for measurement (mm)	< \varnothing 12
Max. open jaw (mm)	\varnothing 12
Battery powered	2 x AAA (R03 / LR03)
Dimensions (L x W x D) mm	235 x 60 x 32
Weight (approx.) grams	250 (without battery)

3. Measurement accuracy

Function	Range	Res.	Accuracy
True RMS ACV < 0.N display 'Auto' >700V alarm sound >748V display 'OL'	>0.700 - 3.999V 40.00V 400.0V 745V	0.001V 0.01V 0.1V 1V	+/- 1.0% of rdg +/-5 digit +/- 1.0% of rdg +/-5 digit +/- 1.0% of rdg +/-5 digit +/- 1.0% of rdg +/-5 digit
DCV < 0.7V display 'Auto' > 900V alarm sound > 998V display 'OL'	> 0.700 - 3.999V 40.00V 400.0V 995V	0.001V 0.01V 0.1V 1V	+/- 1.0% of rdg +/-5 digit +/- 1.0% of rdg +/-5 digit +/- 1.0% of rdg +/-5 digit +/- 1.0% of rdg +/-5 digit
True RMS AC current < 2.0A display 'Auto' > 219.9A display 'OL'	> 2.0 - 200.0A	0.1A	+/- 1.5% of rdg +/-5 digit
DC current < 2.0A display 'Auto' > 219.9A display 'OL'	> 2.0 - 200.0A	0.1A	+/- 1.5% of rdg +/-5 digit
Continuity check Audible sound when <500Ω (approx.)	>50.0Ω	0.1Ω	+/- 1.0% of rdg +/-5 digit
Resistance 0-40MΩ >39.95MΩ (approx.) display 'OL'	40.0Ω 4.000KΩ 40.00KΩ 400.0KΩ 0.400 - 4.000MΩ 40.00MΩ	0.1Ω 0.001KΩ 0.01KΩ 0.1KΩ 0.001MΩ 0.01MΩ	+/- 1.0% of rdg +/-5 digit +/- 1.0% of rdg +/-5 digit +/- 1.0% of rdg +/-5 digit +/- 1.0% of rdg +/-5 digit +/- 2.0% of rdg +/-5 digit +/- 2.0% of rdg +/-5 digit

4. Component descriptions

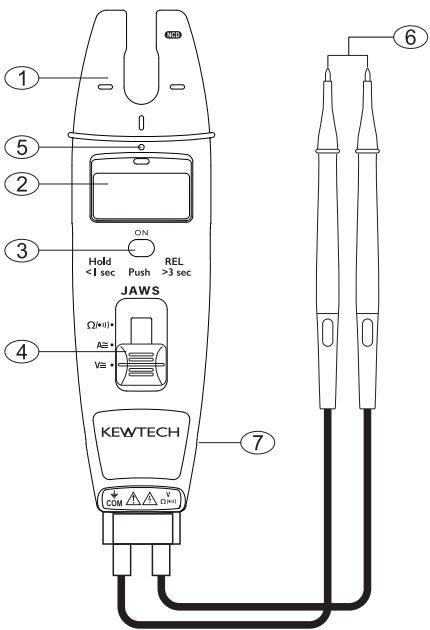

- ① AC / DC current sensor
- ② LC Display
- ③ Press button (⏻ / Hold / Rel.)
 - a) Press once to power ON
 - b) Press for >5 secs. to power OFF
 - c) Press for <1 sec / freeze the reading
 - d) When measuring, press for >3 secs. to 'zero' the reading (relative reading)
- ④ Function slide switch
 $\Omega / \bullet || \rightarrow A \approx \rightarrow V \approx$
- ⑤ Automatic backlight sensor
ON / OFF the backlight
- ⑥ Test probe
- ⑦ Battery compartment

5. How to replace batteries

Loosen the screw of battery cover and replace 2 AAA alkaline type battery according to proper polarity indicated inside the battery compartment. Then, tighten the screw.

To avoid chemical leakage from the batteries, remove them if you are not intending to use the instrument for an extended period of time.

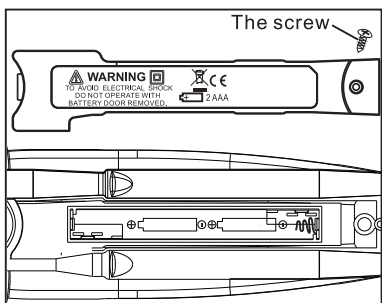

6. Explanations of symbols and units on the instrument

~ Alternating voltage

≡ Direct voltage

A Ampere

mV Millivolt (unit of electrical potential)

V Volt (unit of electrical potential)

⊖ Negative

188.8 Freeze / Hold reading

Ω Ohm (unit of electrical resistance)

KΩ Kilo Ohm

MΩ Mega Ohm

AUTO Auto range measurement

CAT IV Over-voltage category 4

CAT III Over-voltage category 3

⊥ Ground potential

OL Over-range

🔋 Low battery display

7. Intended use

Measuring and displaying electrical voltage category III 600 V (against ground potential, according to EN 61010-1) up to a maximum or lower than 600V.

- Measuring AC / DC Voltage up to 745V AC / 995V DC.
- Measuring AC / DC current up to 200 A
- Measuring resistance up to 40.00 M Ω
- Continuity check with buzzer sound <500 (approx.)
- Measuring operation is only permitted with the stated battery type 2 AAA (R03/ LR03)

 The measuring instrument must not be operated when battery compartment is open.

Do not use:

- In damp, wet or high humidity conditions.
- With wet hands.
- Where dust / flammable gasses / vapour or solvent is present.
- In thunderstorms or in similar conditions with high electrostatic fields etc.

 Any use other than the one described above will damage the product. Moreover, this involves dangers such as short circuit, fire, electric shock, etc. No part of the product must be modified or re-built. This instrument indicates measured values on a 2000 count digital display. The measuring value display of the clamp meter comprises 2000 count.

 Never attempt to make any measurements if any abnormal conditions such as a broken case or exposed metal parts are present on the instrument or test leads and probes. The individual measuring ranges are selected via the slide switch ④. The safety instructions must be followed unconditionally!

CAT.III	Primary electrical circuits of the equipment connected directly to the distribution panel, and feeders from the distribution panel to outlets.
CAT.IV	The circuit from the service drop to the service entrance and to the power meter and primary overcurrent protection device (distribution panel).

8. Safety instructions

-  Please read the operating instructions carefully before using the product for the first time as they include important information necessary for correct measurement.







The guarantee becomes null and void when damage has incurred as a result of non-compliance with the operating instructions. We do not assume any liability for any damage arising as a consequence.

We will also not assume any responsibility for damage to assets or for personal injury caused by improper handling or failure to observe the safety instructions.

This device left the manufacturer's factory in a safe and sound condition.

The user must observe the safety instructions and warnings contained in this operating manual for safe operation and also qualify for warranty claims.

Please note the following symbols:

-  A triangle containing an exclamation mark indicates important information in these operating instructions which are to be observed without fail.
-  A triangle containing a lightning symbol warns of danger of an electric shock or of the impairment of the electrical safety of the device and may cause serious or fatal injury.
-  The 'hand' symbol indicates special information and advice on operation of the device.
-  Complies with EMC and Low Voltage directive.
-  Class 2 insulation (double or reinforced insulation).
-  Ground potential.

Do not dismantle or make any modifications to this instrument.

Verify proper operation on a known source before use or taking action as a result of indication after use.

Consult an expert when in doubt about the operation, the safety or the connection of the device.

9. Measurements

 Do not exceed the maximum permitted input values.

 Before measuring, check the instrument and test leads for any cuts, cracks or squashed leads. If any defects the instrument must not be used. **Fatal danger!**

A) Voltage 'V \approx ' measurements

Proceed as follows to measure AC / DC voltages:

- Set the slide switch ④ to the correct measuring range: **V \approx** for AC / DC voltage.

- Connect the two test probes to the object to be measured ie: battery, circuit etc.

The red measuring probe indicates the positive pole, the black probe indicates the negative pole.

- The polarity of the respective measured value is indicated together with the measured value.

As soon as a minus '-'

 appears for the direct voltage in front of the measuring value, the measured voltage is negative (or the test leads polarity is mixed up).

 Whenever at 'Auto power OFF', press the button to wake up the meter.

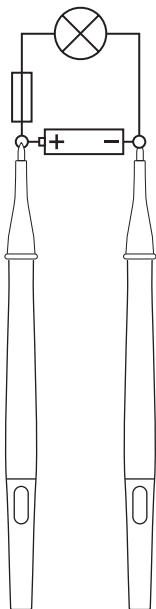

B) Resistance measuring 'Ω'

⚠ Make sure that all the circuit parts, switches and components and other objects of measurement are disconnected from any voltage at all times.

Proceed as follows to measure the resistance:

- Set the slide switch ④ to select the resistance measuring range 'Ω ●))'.
- Check the measuring leads for continuity by connecting both measuring probes to one another. After that the resistance value must be approximately 0.000Ω. (Press and hold > 3 secs the 'Rel' ③ button to 'zero' the reading).
- Now connect the measuring probes to the object to be measured. As long as the object to be measured is not high-resistive or open circuit, the measured value will be indicated on the display.
- As soon as 'OL' Over range appears on the display, you have exceeded the measuring range or the measuring circuits has been interrupted.

☞ If you carry out a resistance measurement, make sure that the measuring points which you contact with the test probes are free from dirt, oil, solderable lacquer or the like. An incorrect measurement may result under such circumstances.

⚠ If the instrument powers off during measurement, remove the test leads from the circuit under test.

Turn on and conduct a voltage check on the circuit.

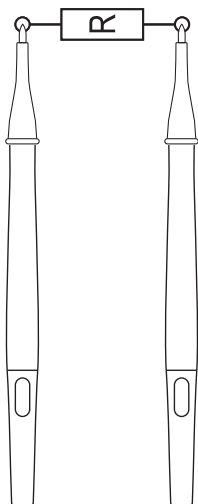

C) Continuity check 'Ω •)))'



Make sure that all the circuit parts, switches and components and other objects of measurement are disconnected from any voltage at all times.

- Set the slide switch ④ to select the resistance measuring range 'Ω •)))'.
- Check the measuring leads / or continuity by connecting both measuring probes to one another. After that the resistance value must be approximately $<2.0\Omega$. (Press and hold > 3 secs the 'Rel' ③ button to 'zero' the reading).
- Now connect the two measuring probes with the object to be measured (circuit).
- The display shows in Ohm with buzzer sounds when $<50\Omega$.



If you carry out continuity measurement make sure that the measuring point which you contact with the test probes are free from dirt, oil, solderable lacquer or the like. An incorrect measurement may result under such circumstances.



If the instrument powers off during measurement, remove the test leads from the circuit under test. Turn on and conduct a voltage check on the circuit.

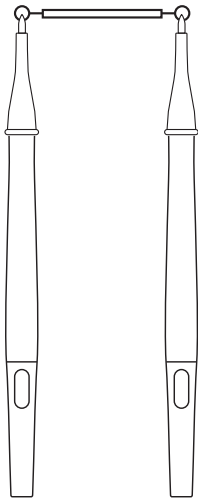

C) AC / DC current measurement

- Set the slide switch ④ to the A \approx range.
- If the reading on LC display is greater than 0.01A, press the 'Rel' button to zero the reading.
- Place the conductor to be measured inside the open jaw current sensor.
For optimum results, put the conductor at the bottom of the jaw, in line with the positioning markings.
- Observe the reading on the LC display.

Note: ⚠ ⚡ **REMOVE TEST LEADS WHEN MEASURING CURRENT!**

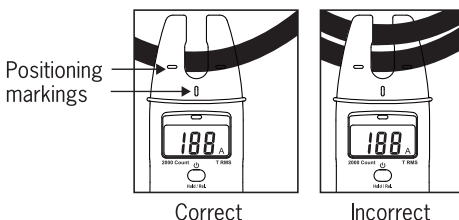

Troubleshooting

⚠ Always adhere to the safety instructions!

Error	Possible cause
The instrument does not function.	Are the batteries flat? Check their status.
Measured value does not change.	Is the wrong range selected?
Reading on display hangs up.	Press the Power button to power OFF the meter and then start again after 3 secs.
Fatal error or undefined reading.	Press the Power button to power OFF the meter and then start again after 3 secs.

⚠ Actions other than those described should only be carried out by an authorised specialist.

KEWTECH

Certificate
of Conformity &
Warranty Registration

This instrument has been calibrated using equipment which has itself been calibrated to standards traceable to International Standards monitored by BIPM (International Bureau of Weights and Measures)

This certificate guarantees that the product has been fully inspected and conforms to all the relevant published specifications.

Free Two Year Warranty

Kewtech's Two Year Warranty enhances the customers' legal rights/ it covers all manufacturing defects for a two year period but Kewtech reserves the right to exclude abuse or accidental damage.

To register your free guarantee simply go to kewtechcorp.com - the link is on the home page.

Re-calibration Service

Regular re-calibration is recommended for this instrument. Kewtech recommends that with normal use the instrument is calibrated at least once in every 12 month interval.

When the instrument is due for re-calibration return it to the address below marked for the attention of the Calibration Department.

Kewtech Corp Ltd
Shaw Wood Business Park
Shaw Wood Way
Doncaster DN2 5TB
t: 01302 761044

kewtechcorp.com