

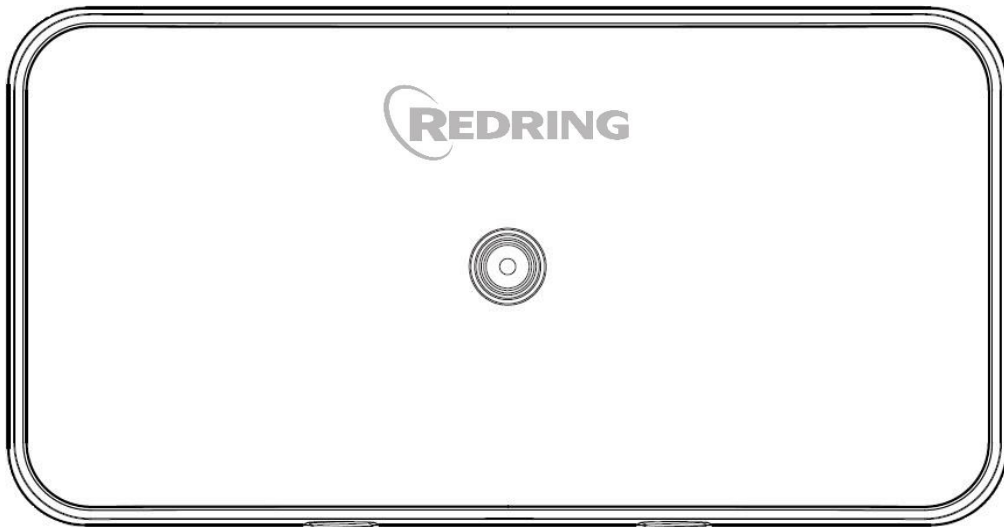

**POWERSTREAM  
UNVENTED INSTANTANEOUS WATER HEATER**



**Installation and User Guide**

**IMPORTANT:**  
**This booklet should be left with the user after  
installation and demonstration.**

**It should be kept in a safe place, as you may need to refer to it for  
general instructions or future maintenance.**

## INTRODUCTION

Thank you for purchasing a quality Redring Powerstream unvented instantaneous water heater. **To enjoy your new unit at its best, please read this manual thoroughly to familiarise yourself with all instructions BEFORE beginning installation or using the appliance.**

**If you experience any difficulty with the installation or operation of your new water heater, then please refer to the "What to do if things go wrong" section in this manual before contacting us.**

## IMPORTANT SAFETY INFORMATION



THERE IS A RISK OF PERSONAL INJURY.



THERE IS A RISK OF DAMAGING TO APPLIANCE.

	<p>THIS APPLIANCE MUST BE INSTALLED, COMMISSIONED AND SERVICED BY A QUALIFIED PERSON IN ACCORDANCE WITH THE NATIONAL AND LOCAL REGULATIONS IN FORCE IN THE COUNTRY OF INSTALLATION. ALSO TAKE INTO CONSIDERATION.</p> <ul style="list-style-type: none"> <li>• HEALTH AND SAFETY AT WORKS ACT</li> <li>• IET REGULATIONS</li> <li>• BS CODES OF PRACTICE</li> <li>• LOCAL AND NATIONAL BUILDING REGULATIONS</li> <li>• LOCAL AND NATIONAL WATER REGULATIONS</li> </ul>
	THIS APPLIANCE MUST BE INSTALLED FOR HAND WASHING OR SHOWERING ONLY. NOT INTENDED FOR CONSUMPTION, WASHING DISHES OR USE IN A COMMERCIAL KITCHEN.
	THIS APPLIANCE CAN BE USED BY CHILDREN AGED FROM 8 YEARS AND ABOVE AND PERSONS WITH REDUCED PHYSICAL SENSORY OR MENTAL CAPABILITIES OR LACK OF EXPERIENCE AND KNOWLEDGE IF THEY HAVE BEEN GIVEN SUPERVISION OR INSTRUCTION CONCERNING USE OF THE APPLIANCE IN A SAFE WAY AND UNDERSTANDING THE HAZARDS INVOLVED. CHILDREN SHALL NOT PLAY WITH THE APPLIANCE. CLEANING AND USER MAINTENANCE SHALL NOT BE MADE BY CHILDREN WITHOUT SUPERVISION.
	THIS APPLIANCE IS INTENDED TO BE PERMANENTLY CONNECTED TO THE FIXED ELECTRICAL WIRING OF THE MAINS SUPPLY WITH ITS OWN DEDICATED SUPPLY.
	ENSURE THAT THE MAINS WATER SUPPLY MEETS THE REQUIREMENTS FOR YOUR SPECIFIC MODEL POWERSTREAM LISTED ON PAGE 3 & 4 OF THIS INSTRUCTION BOOKLET.
	THIS APPLIANCE MUST NOT BE FITTED IF DAMAGED IN ANYWAY OR WHERE IT MAY BE SUBJECTED TO FREEZING CONDITIONS. DO NOT SWITCH THE APPLIANCE ON IF YOU SUSPECT IT OF BEING FROZEN. WAIT UNTIL YOU ARE SURE IT HAS THAWED OUT.
	THE UNIT MUST NOT BE FITTED TO ANY TYPE OF THERMOSTATIC MIXER VALVE / TAP, PERCUSSION STYLE OR 'JOYSTICK' STYLE TAPS. CAN RESTRICT HOT FLOW AND CUT-OUT UNIT.
	THIS APPLIANCE MUST ONLY BE USED FOR HEATING WATER PROVIDED TO A HAND WASHING SINK OR SHOWER. THIS PRODUCT IS NOT SUITABLE FOR KITCHEN SINKS OR BATHTUBS.
	IF A NON-RETURN VALVE IS FITTED IN THE INLET FEED TO THE UNIT, THEN THE INSTALLATION MUST ALSO INCLUDE A 3.5 BAR PRESSURE REDUCING VALVE AND A 6 BAR PRESSURE RELIEF (EXPANSION) VALVE.
	ISOLATE THE MAINS ELECTRICAL & THE WATER SUPPLY APPLIANCE BEFORE SERVICING, MAINTENANCE OR CLEANING.
	ONLY CLEAN THIS PRODUCT WITH A DAMP MICROFIBER CLOTH – DO NOT USE HARSH CHEMICALS THAT MAY TARNISH THE APPLIANCE.
	DURING OPERATION PARTS & SURFACES MAY BECOME HOT – AVOID ACCIDENTAL CONTACT.
	DO NOT COVER APPLIANCE.
	THIS APPLIANCE IS NOT SUITABLE FOR OUTDOOR USE OR AN AREA WHERE WATER JET COULD BE USED.

## HOW YOUR POWERSTREAM WORKS

The Powerstream instantaneous water heater is designed to provide instant hot water at a fixed heating capacity. By opening the water outlet, tap or shower the appliance flow switch activates and in turn energizes the heating element. The neon light on the front of the appliance is illuminated whenever heating is on.

As the water is instantly heated with a fixed power capacity, the appliance output temperature varies depending on:

- The temperature of the mains water supply.
- The water flow rate, i.e. volume of water through the unit.
- The power consumption of the unit.

The temperature of the main water supply can vary from 5°C in winter up to about 20°C in summer, with an average of about 12°C. The charts below show the water temperature (°C) you can expect from the unit, operating at 9.5/10.8/12.0kW for the different flow rates (in litres/minute).

Model	Expected Temperature	Water Flow Rate (l/min)				
		3.0	4.0	5.0	6.0	7.0
9.5kW	Summer (°C)	70	54	48	43	40
	Winter (°C)	55	40	33	28	25
10.8kW	Summer (°C)	-	59	51	46	41
	Winter (°C)	-	44	36	31	26
12kW	Summer (°C)	-	62	54	49	44
	Winter (°C)	-	48	39	34	30

Recommended Temperature °C				
min	max	min	max	X
32	40	36	40	
Recommended Flow Rate (l/min)				
min	max	min	max	X
3.0	7.0	5.0	7.0	

This means that with the 12.0kW unit you can shower at 39°C with a flow rate of 5 litres/minute in the middle of winter. The Powerstream appliance is intended to supply up to two wash hand basins or one wash hand basin and one shower application. It cannot deliver the temperature and flowrate combination required to fill a bathtub.

**! This appliance must NOT be used for commercial applications or applications where high temperatures at high flow rates are required, i.e. dishwashing or for filling baths.**

The unit includes a dual thermal cut-out (diagram 1) which is attached to the heat exchanger tube. It will switch off the heater elements if the waterflow is reduced too much and the temperature goes above a set limit.

The first stage cut-out is cyclic and will automatically reset as the water temperature falls. The unit will then function normally again.

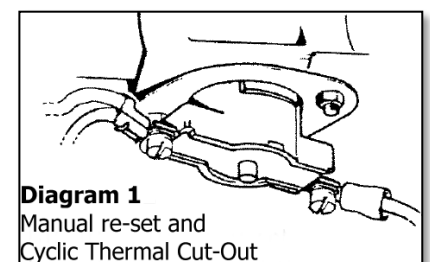

The second stage cut-out when triggered needs to be reset manually inside the unit. This cut-out will only operate in exceptional circumstances or if the product is being used outside of its scope of suitable uses. (diagram 1)

The unit can supply two outlets – for example, a shower and a basin, or up to two basins – but water from the unit will be shared between the outlets. This is particularly important if a unit supplies a shower and a basin, as the basin should not be used while someone is using the shower. The unit is NOT to be fitted to a bath or kitchen sink other than for hand-washing purposes.

## HOW TO INSTALL YOUR *POWERSTREAM*



**THIS APPLIANCE MUST BE INSTALLED, INITIALLY COMMISSIONED AND SERVICED BY A QUALIFIED PERSON IN ACCORDANCE WITH THE NATIONAL AND LOCAL REGULATIONS IN FORCE IN THE COUNTRY OF INSTALLATION.**



**DO NOT INSTALL WHERE IT MAY BE SUBJECTED TO FREEZING CONDITIONS.**

**Diagram 2a**  
Examples of fitted units

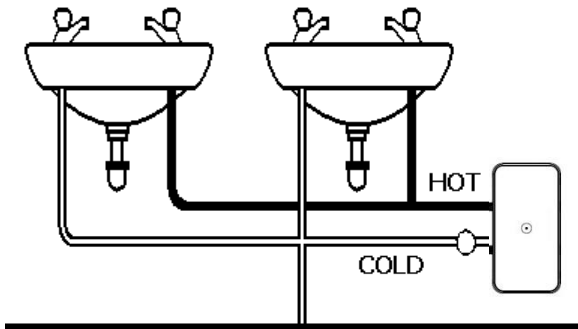

**Diagram 2b**  
Acceptable unit orientation

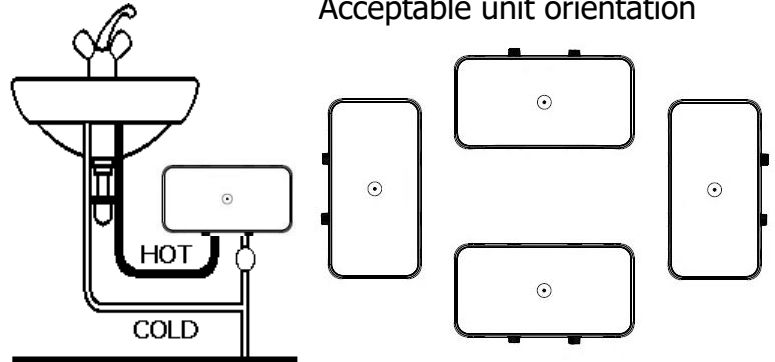

The Powerstream is recommended to supply a **MAXIMUM** of two washbasins (see diagram 2a) **OR** a washbasin and shower (see diagram 5b).

If the Powerstream is connected to a mixer tap, then only **NON**-Thermostatic types should be used (water mixes at the outlet pipe only).

The Powerstream is **NOT** to be fitted to a bath or kitchen sink other than for hand-washing purposes. (See product flow rate tables on page 3).

### **BEFORE YOU START**

For mains electrical connection and associated information please refer to page 7 of this booklet. Check the pressure of the main water supply, 1 bar – 6 bar. The appliance must not be directly connected to a water supply greater than 6bar. If mains pressure is greater than 6 bar please refer to page 5.

To operate correctly, the unit requires the following - 1-6bar and 3-4L/min.

### **FIXING THE UNIT TO THE WALL**

#### **Deciding the position**

- If being used in a public place, position the unit out of reach to discourage vandalism.
- Fit the unit onto a flat piece of wall, well away from any potential splashes of water or spray.
- Position the unit either upright or lengthways (diagram 2a/b), whichever is most convenient for plumbing and wiring, keeping the hot water pipe length to a minimum (less than 3m is recommended) and insulate the pipe in order to save energy.
- If the unit is to supply a basin, you can fit it either above or below the basin.

## Wiring Lug Removal

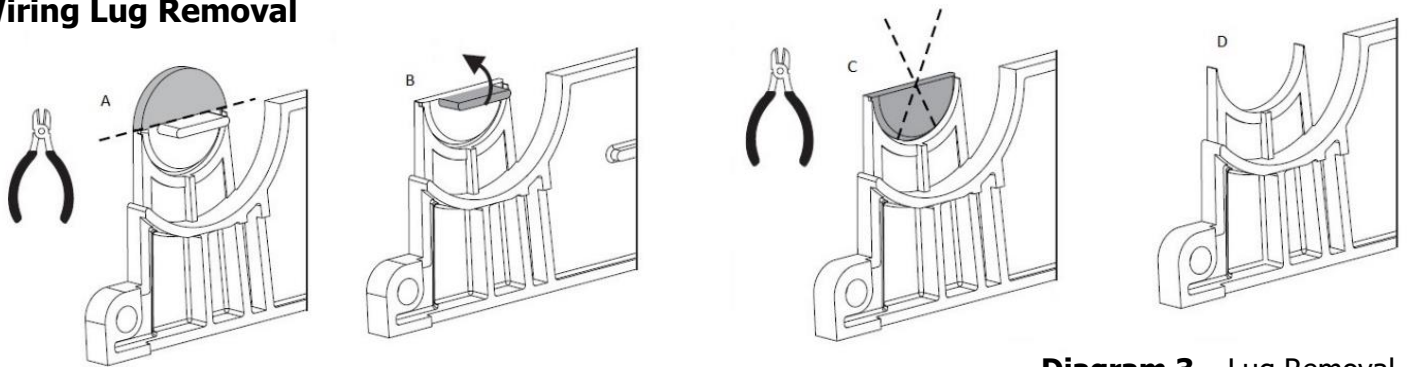

**Diagram 3** – Lug Removal

- Follow steps A-D in Diagram 3 above to remove plastic lug.
- Feed cable through rubber gland in metalwork.

**Diagram 4** – Back Plate

## Fixing to the wall

- Undo the retaining nuts and take the front cover off the unit. Hold the backplate in position against the wall whilst you mark the four fixing holes.
- Drill the holes and fix the unit to the wall using the screws supplied.

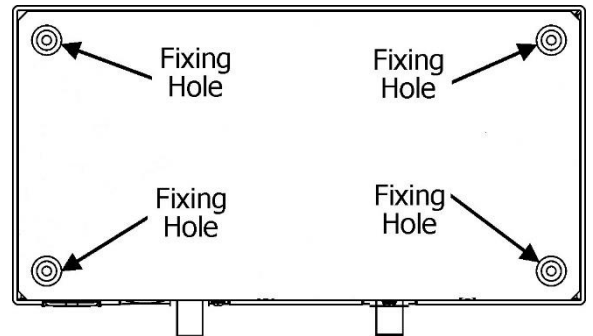

## Hydraulic Connections



**IF A NON-RETURN VALVE IS FITTED AND/OR THE INLET FEED TO THE UNIT IS GREATER THAN 6BAR, THEN THE INSTALLATION MUST ALSO INCLUDE A 3.5 BAR PRESSURE REDUCING VALVE AND A 6 BAR PRESSURE RELIEF (EXPANSION) VALVE AS SHOWN IN DIAGRAM 5a.**

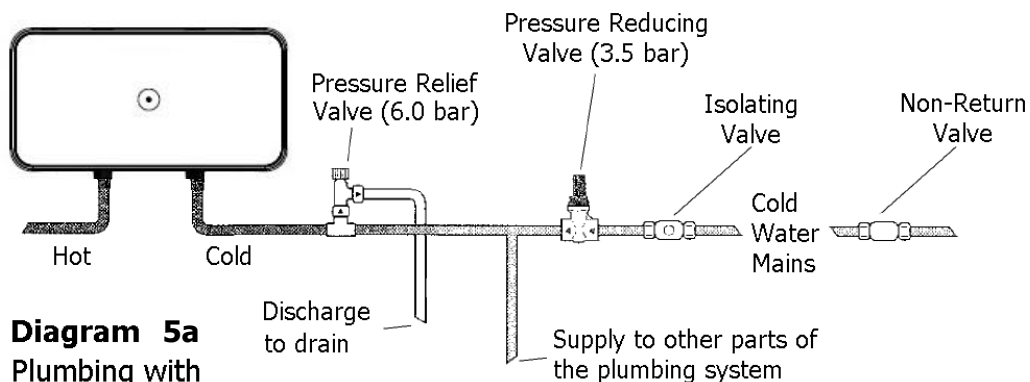

**Diagram 5a**  
Plumbing with  
Non-Return Valve

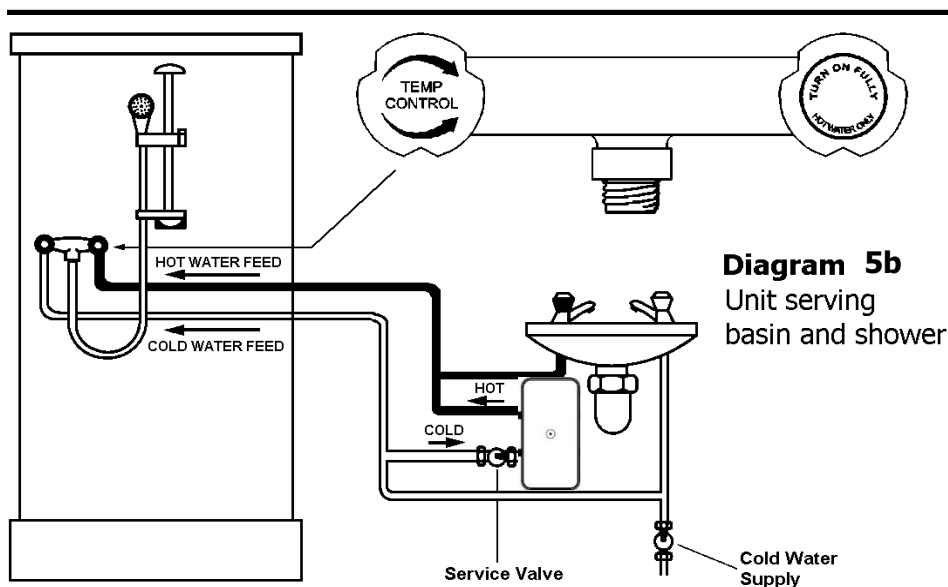

**Diagram 5b**  
Unit serving  
basin and shower



**ENSURE THAT THE MAINS WATER SUPPLY MEETS THE REQUIREMENTS LISTED ON PAGE 4 BEFORE CONTINUING WITH INSTALLATION.**



**BEFORE CONNECTING THE PIPE WORK TO THE POWERSTREAM, ENSURE THAT THE PIPE WORK IS FULLY FLUSHED OUT.**

## Fitting the pipes

- The unit should be connected directly to the main cold-water supply. A gauze filter should be incorporated to prevent any debris entering the venturi.
- For the inlet and outlet connections Ø15mm copper or stainless-steel pipe must be used. Plastic pipe of any kind cannot be used.
- Use PTFE tape for making screw joints. Do not use a jointing compound as it can enter the unit and cause damage to the flow switch mechanism.
- Remember to keep the hot water pipe runs as short as possible (Ideally less than 3m) and insulate this piping especially on longer runs.
- If the unit is to supply more than one basin outlet, the height should be the same at each outlet if they are to be used at the same time. If not, one outlet will take all the water.  
In some cases, it may be worth fitting a second unit.
- When the pipework has been plumbed in, flush it through with water before you connect the unit, to remove any swarf or loose particles.

## Connecting the unit to the pipes

- The inlet and outlet are clearly marked on the unit. All models have Ø15mm straight shank connections.
- The unit comes with a service valve (diagram 6) which must be fitted on the inlet of the unit. The valve can be used to turn off the water supply to the unit if it needs servicing, or to reduce the main supply flow if it is too high (see "commissioning" section on page 8).

## Fitting the attachments

- If the unit is to supply a shower, you will also need a "Redring Mixer Unit". Available in chrome finish and suitable for surface or concealed pipe entry (see page 9 for details). Only the approved shower mixer unit (300001357) is guaranteed to operate with this product.
- If the unit is to supply a shower, and the shower handset can reach water in a bath or basin, you must fit a vacuum breaker to comply with Water By-laws.  
Alternatively, use the hose-retaining feature built into the soap dish.

Because water can sometimes seep through, you should position the vacuum breaker where dripping will not do any damage.

- If the unit is to supply a basin or two basins, we recommend that you use "¼ turn lever control spray taps" (see page 13).

**Diagram 6**

Service Valve supplied with:

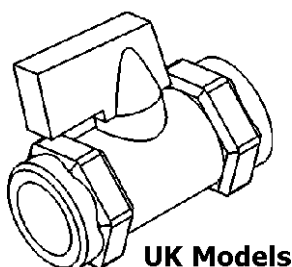

This information shows how our products pass relevant European Union Energy Directives (ErP).

Manufacturer	<b>Redring</b>		
Product	<b>RPS95</b>	<b>RPS108</b>	<b>RPS12</b>
Load Profile	XS	XS	XS
Efficiency	A	A	A
Efficiency %	39	39	39
Consumption (kWh / annum)	473	468	469
Sound (dB)	15	15	15
Precautions	Ensure all product installation, maintenance and care instructions are followed as listed here.		



## MAKING THE ELECTRICAL CONNECTIONS



### THIS WATER HEATER MUST BE EARTHED.

The electrical installation must be made by a competent person in accordance with the current BS.7671 (IET Wiring Regulations) and "Part P" of the Building Regulations and/or local regulations.

### Wiring to the mains (Check the unit rating to see which applies).

Rating	Fuse/MCB	Isolating Switch	Cable Size
9.5 kW	40 amps	40 amps	6 mm <sup>2</sup> / 10 mm <sup>2</sup> *
10.8 kW	45 amps	45 amps	10 mm <sup>2</sup>
12.0 kW	50 amps	50 amps	10 mm <sup>2</sup> / 16mm <sup>2</sup> *

\* For cable runs over 10 meters or where cable is not flat clipped and surface mounted, the larger size is the minimum required, as per BS.7671.



**A means of local isolation and protection to the appliance is recommended i.e. 50A fused spur.**



**A 50A RCBO circuit breaker with 30mA sensitivity must be fitted at the local consumer unit on the same supply, or as BS.7671.**

### If the unit is fitted in a Bathroom:

9.5 kW and 10.8 kW Powerstream: A standard 45 Amp cord operated isolator switch is recommended.  
12.0 kW Powerstream: A double pole 50 Amp isolator switch is required. This must be mounted out of reach of the shower cubicle or bath.

### Wiring the Powerstream

- The unit has been designed to accept up to 16mm<sup>2</sup> supply cable. 6mm<sup>2</sup> & 10mm<sup>2</sup> cable can be used as required. In all cases the outer sheath of the cable **MUST** project through the grommet (diagram 7). This will prevent water getting into the unit.
- Strip back the insulation on the **LIVE** (brown or red), **NEUTRAL** (blue or black) & **EARTH** (green/yellow or green) mains wires about 8mm.
- Feed the cable through the entry grommet.
- Connect the cables to the terminal block (diagram 7).
- Make sure that the live, neutral & earth terminal block screws are tightened securely (1N/m minimum).
- Fit the front cover and tighten the retaining screws.



**Failure to comply with these instructions could result in failure of the terminal block.**

### Ensuring the earth continuity

- If the unit is fitted in a bathroom, to conform with the current BS.7671 (formally IET regulations), the units earth continuity conductor must be effectively connected to **ALL** exposed metal parts of **ALL** other appliances in the room. The pipe work must be bonded.

**Diagram 7**

Cable Termination

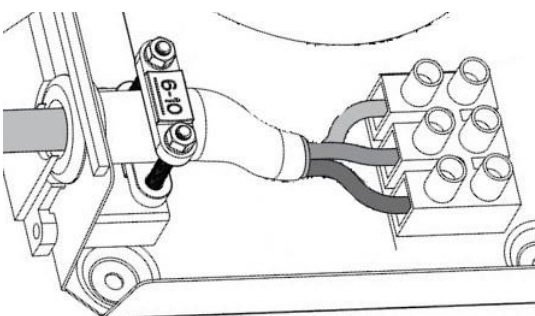

**Diagram 8**

Wiring Diagram

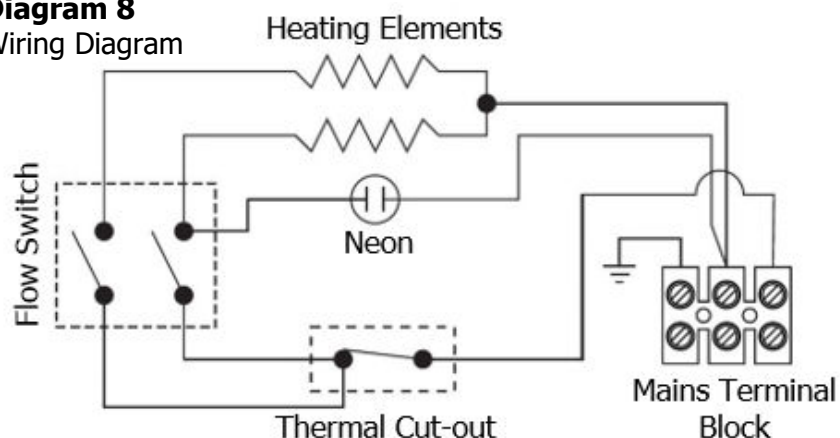

## CHECKING FOR LEAKS

- Let the water run through the unit for a few seconds.
- Close the outlet and check that no pipe joints leak.

## ADJUSTING THE SERVICE VALVE

- If the unit is to supply a basin:
  - Turn on the hot water tap fully at the basin.
  - Turn the service valve on slowly until the neon illuminates on the product (max temperature).
  - Adjust the service valve until the water comes out of the tap at the required temperature. Allowing for the temperature of the water to settle after each adjustment.
  - Check that the unit works correctly when the basin tap is closed and then opened again: if not, adjust the service valve slightly.
- If the unit is to supply a shower,
  - Turn the hot water tap on the mixer unit fully on.
  - Turn the service valve clockwise until the neon light goes out, then turn it back until the neon just comes on.
  - Check the water temperature at the handset and, if necessary, turn the cold tap on and adjust to get the desired shower temperature.



**YOU MUST REGULARLY INSPECT THE SHOWER HOSE FOR WEAR AND DAMAGE. REPLACE IF NECESSARY.**



**TO MAINTAIN THE PERFORMANCE OF YOUR SHOWER, YOU MUST DESCALE THE SHOWER HANDSET REGULARLY.**

All water contains particles of lime-scale, which build up in the shower handset and unit reducing the performance. It is therefore important to clean the shower handset by simply rubbing the rubber nozzles or soaking in proprietary lime-scale remover and rinsing thoroughly before use. The frequency of this will depend on water hardness and experience.



**The hot water tap should be turned fully on, at all times i.e. every use, so that the unit will operate correctly. Restricting the flow may cause the unit to cut out.**



**The water heater must be mounted on a vertical wall or surface and positioned with water connections as shown in Diagram 2b.**



**The unit should be connected directly to the main cold water supply and not to pre-heated water. The unit should be installed with service valves on the inlet. These valves can be used to turn off the water supply to the unit if it needs servicing, or to reduce the water flow if it is too high.**



# HOW TO USE YOUR *POWERSTREAM*



**DO NOT USE THE UNIT IF YOU THINK IT MAY BE FROZEN, AS THIS COULD RESULT IN SERIOUS DAMAGE TO THE UNIT. WAIT UNTIL YOU ARE SURE THAT IT HAS COMPLETELY THAWED OUT BEFORE YOU SWITCH ON.**

## Basin

- Check that the power is switched on at the mains isolator switch.
- Turn on the hot water tap **FULLY** at all times. If you do not turn the tap on fully, you will find that the temperature of the water will vary. The hot water temperature will have been set using the service valve (diagram 6).
- If the unit has been used recently, run the water through for a few seconds to let the temperature stabilize, we advise you **DO NOT** touch the water flow during this time.



**YOU MAY INITIALLY GET A SHORT BURST OF VERY HOT WATER FROM THE UNIT IMMEDIATELY UPON OPENING THE TAP.**

- If a second tap connected to the unit is also turned on, the hot water will be shared between the two and so the flow will drop.

## Shower

- Check that the power is switched on at the mains local isolator switch.
- Turn on the hot (or "flow") tap **FULLY** (diagram 9).
- If the unit has been used recently, run the water through for a few seconds to let the temperature stabilize, we advise you **DO NOT** enter the water flow during this time.



**YOU MAY INITIALLY GET A SHORT BURST OF VERY HOT WATER FROM THE UNIT IMMEDIATELY UPON OPENING THE TAP.**

- Turn on the cold (or "temperature") tap, if necessary, to adjust the temperature of the water.
- Make sure that no other outlets connected to the unit are used whilst you are in the shower, or the water flow will drop suddenly.
- It is important to clean the shower spray plate regularly.
- In order for the Powerstream to function correctly, only the "Redring Mixer Kit" can be used. The kit, Cat No. 300001357, comes complete with full accessories including a 3 position multi-function shower handset.

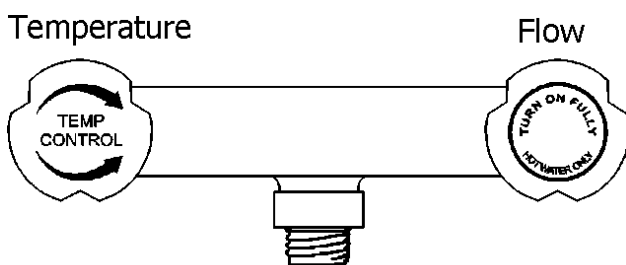

**Diagram 9**  
Redring Shower  
mixing tap

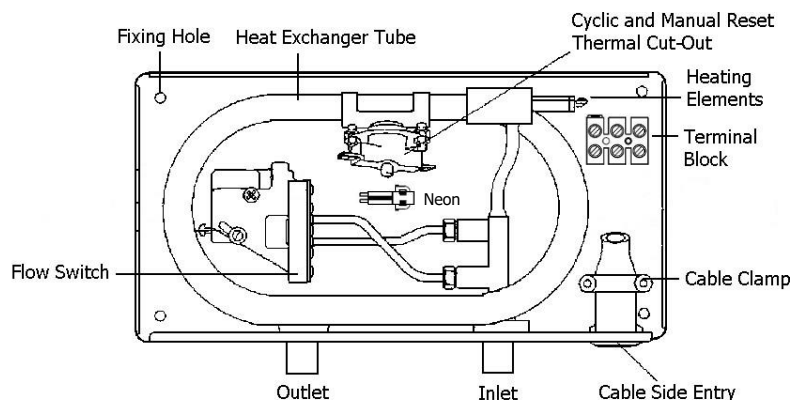

**Diagram 10**  
Internal  
Components

## WHAT TO DO IF THINGS GO WRONG (1)

### SELF HELP

If the unit is not working satisfactorily, make the following checks before calling out the installer. Any one of these adjustments could restore the performance.

Symptom	Cause	What to do
Little or no water flow.	The main water supply is turned off.	Turn on the main supply fully at the stop valve. Set up unit as per commissioning instructions.
Cold water only - neon light off.	The main water supply is not turned on enough.	Turn on the main supply fully at the stop valve.
Water too cold - neon light on.	The water flow rate is too high.  The inlet water temperature has dropped.	Adjust the service valve (see page 8).  Adjust the service valve (see page 8).  For a shower, adjust the spray pattern available on the multi-mode handset.
Water flow too low, or temperature too high.	The main water supply is too low  The hot tap is not fully open.	Increase the supply water flow. Make sure that the service valve is correctly adjusted.  Adjust the service valve so that the water is at the right temperature with the tap fully open (see page 8).  Always turn the hot tap fully on.
Water goes from hot to cold.	The water flow or pressure is too low, and the thermal cut-out is operating.  A second outlet has been turned on.	Increase the supply water flow Make sure that the service valve is correctly adjusted.  Do not use the basin whilst using the shower.
Shower spray pattern deteriorates.	The shower handset is clogged.	Clean the handset using a descaling solution if required.

## REDRING AFTER SALES SERVICE

We offer a technical advisory service on the telephone to installers and other customers with problems in the field.

**Ring 0344 8793588 Or alternatively email us on:  
GDHV.customersupport@glendimplex.com**

Remember to quote the exact type of unit, as written on the front of the unit and on this leaflet. The model and serial number are located on the bottom face of the unit.

Make a note of those numbers here and be sure to quote them if you call for advice.

**Model Number:** \_\_\_\_\_ **Serial Number:** \_\_\_\_\_

**Note: You may be charged for a service call if you do not have the serial number.**

## WHAT TO DO IF THINGS GO WRONG (2)

### PROFESSIONAL SERVICE

If the previous "Self Help" checks fail to restore the performance, you should seek professional help.

The following additional checklist is provided for the benefit of the qualified service person.



**SWITCH OFF THE ELECTRICITY AT THE LOCAL ISOLATOR BEFORE REMOVING THE COVER TO MAKE CHECKS.**

Symptom	Cause	What to do								
Little or no water flows - neon light off.	The water pressure is very low.	Use a pump to boost the supply (1-6bar).								
Cold water only - neon light off.	The main water is connected to the OUTLET of the unit.  The water pressure is too low.  The thermal cut-out has triggered.  The flow switch is not working.	Reconnect the main supply to the INLET (marked in blue).  Use a pump to boost the supply (1-6bar).  Reset it by opening the unit and pushing the button on the cut-out (diagram 1). Before you do this, you must remove the cause of the problem.  Contact Redring (see page 10).								
Water too cold - neon light on.	One element is not working.  The Power Supply Voltage has dropped.	Switch off the electricity supply and check the resistance of the elements. You should get the following readings. <table style="margin-left: 20px;"> <tr> <td>Loading (kW)</td> <td>Resistance (Ohms)</td> </tr> <tr> <td>9.5</td> <td>12.0</td> </tr> <tr> <td>10.8</td> <td>10.6</td> </tr> <tr> <td>12.0</td> <td>9.6</td> </tr> </table> Ensure both microswitches are working  The heater should only draw the following currents: 40 amps for the 9.5kW model 45 amps for the 10.8kW model 50 amps for the 12.0kW model	Loading (kW)	Resistance (Ohms)	9.5	12.0	10.8	10.6	12.0	9.6
Loading (kW)	Resistance (Ohms)									
9.5	12.0									
10.8	10.6									
12.0	9.6									
Water flow too low or temperature too high.	The service valve is fitted to the OUTLET.  There are constrictions in the plumbing.	Fit the service valve to the INLET of the unit.  Check the plumbing. Only use PTFE tape for making pipe joints.								
Water goes from hot to cold.	The service valve is fitted to the OUTLET.	Fit the service valve to the INLET of the unit.								

## SPARE PART DETAILS

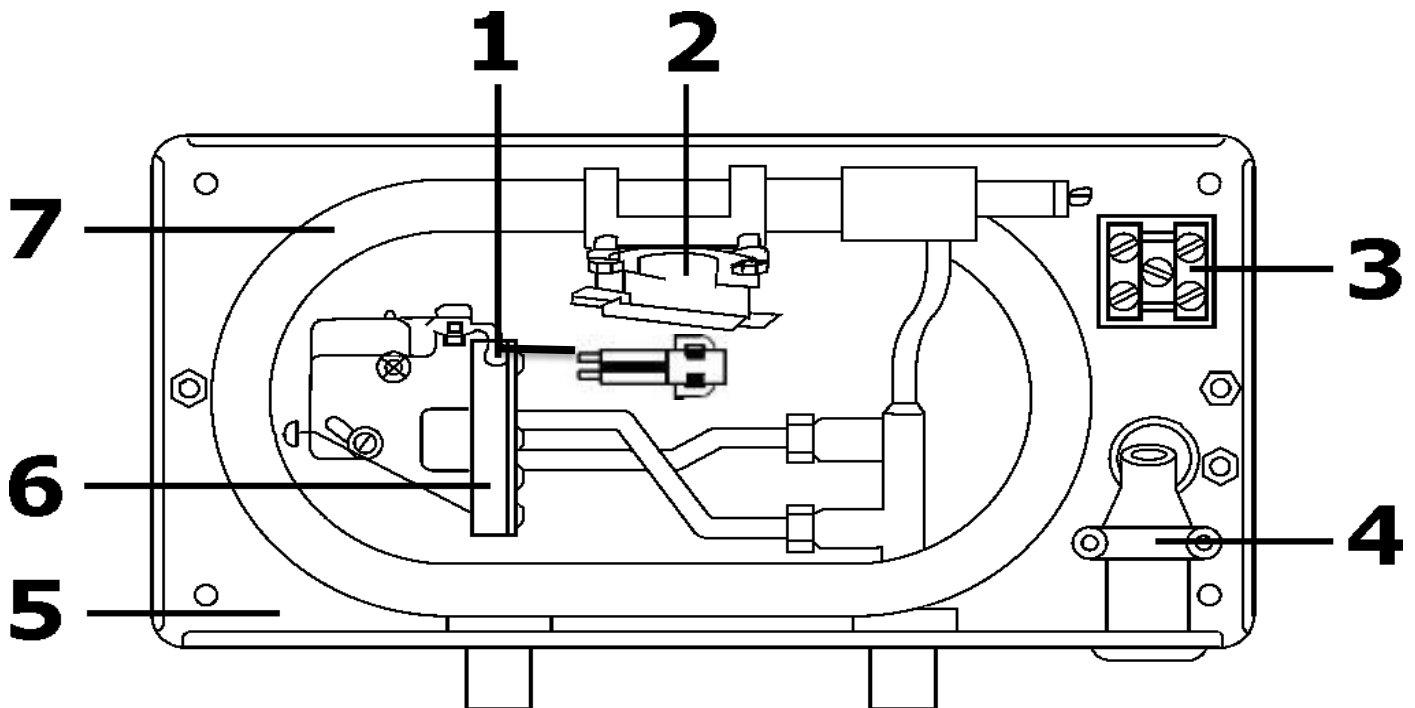

Item.No	Cat.No.	Description
1a	93 79 37 07	Neon & Clip 9.5kW
2	93 79 37 89	Thermal Cut-Out 2-Disc 57/90°C
3	93 79 37 03	Terminal Block 3 way
4	93 79 37 09	Cable Clamp & Rubber Boot
5	30002259	Backplate
6	93 79 38 18	Flow Switch Assy
7a	93 79 38 19	Heat Exchanger Assy (9.5kW 240V)
7b	93 79 38 20	Heat Exchanger Assy 10.8kW 240V)
7c	93 79 38 21	Heat Exchanger Assy (12kW 240V)
Pg. 13	30002291	Front Cover & Trims
Pg. 13	30002293	Front Cover Fixing Screws
Dia. 6	93 79 37 57	Gate Valve

## APPLICABLE MODELS

<b>Cat No:</b>	<b>078931</b>	<b>RPS95 Powerstream Heater</b>	<b>9.5kW</b>	<b>240V IPX4</b>
<b>Cat No:</b>	<b>078421</b>	<b>RPS108 Powerstream Heater</b>	<b>10.8kW</b>	<b>240V IPX4</b>
<b>Cat No:</b>	<b>078438</b>	<b>RPS12 Powerstream Heater</b>	<b>12kW</b>	<b>240V IPX4</b>

## PRODUCT DIMENSIONS

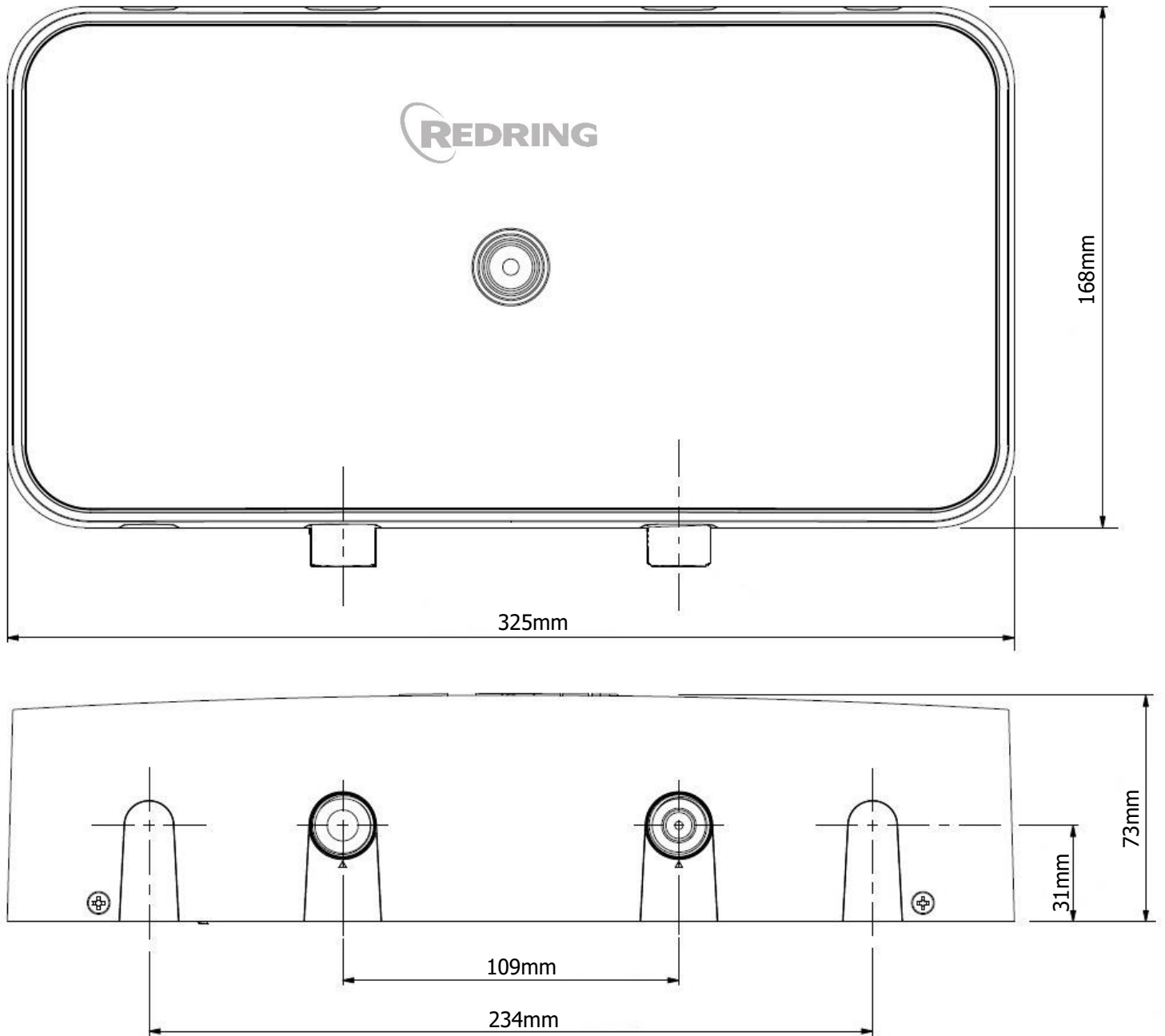

## ADDITIONAL ACCESSORIES

Please Note: The fitting of Spare Parts must be supervised by a suitably qualified person.

Chrome shower mixer unit complete with full accessories.

Reding Mixer Kit

¼ turn lever control spray tap

Catalogue No. 300001357

Catalogue No. 85-793616

For further details, including a comprehensive list off accessories and spare parts please visit

[www.redring.co.uk](http://www.redring.co.uk)







## YOUR GUARANTEE



To view the full guarantee terms and conditions scan this QR code using your smartphone or go to <https://www.gdhv.co.uk/guarantee-terms-and-conditions>.

Your Product is manufactured by Glen Dimplex UK operating as Glen Dimplex Heating & Ventilation. GDHV designs and manufactures products to ensure they deliver reliable service for normal use in domestic dwellings and, where specified by us, in light commercial premises.

GDHV products are individually tested before leaving the factory, Your product comes with a 2 year parts and labour guarantee for repair or replacement of faulty goods and/or partial refund in the event that a repair or replacement is not available.

Your guarantee is provided by Glen Dimplex UK Ltd operating as Glen Dimplex Heating & Ventilation Ltd, Millbrook House, Grange Drive, Southampton SO30 2DF. Terms and conditions apply.

The GDHV guarantee does not in any way diminish or affect your statutory consumer rights in connection with your product.

If you experience a problem with your product during or after the guarantee period, visit our online help centre: <https://www.dimplex.co.uk/gdhv-help-centre>.

If you cannot solve your issue online, contact the customer care team on 0344 879 3588.

Please note that when you contact us you will need to provide the model and serial number of your product and a description of the fault which has occurred.

### Contact Redring

If you have any questions about what the Redring warranty covers and does not cover or how to claim under Redring warranty, please contact us using the information below.

### Contact details

Glen Dimplex UK Ltd  
Millbrook House, Grange Drive, Hedge End,  
Southampton, SO30 2DF Telephone: +44 (0) 344  
879 3588  
Email: [GDHV.customersupport@glendimplex.com](mailto:GDHV.customersupport@glendimplex.com)  
<http://www.redring.co.uk>

Glen Dimplex Europe Ltd  
Airport Road, Cloghran,  
Co. Dublin, K67 VE08, Ireland  
ROI Telephone: +353(0)1 842 833  
Email: [serviceireland@glendimplex.com](mailto:serviceireland@glendimplex.com)

### International

Warranty: Contact your local distributor or Redring direct for details.

Technical advice and service: Contact your local Redring distributor.

Redring: A brand of Glen Dimplex UK Ltd, trading as Glen Dimplex Heating & Ventilation. Glen Dimplex ©. All rights reserved. The material contained in this publication may not be reproduced in whole or in part, without prior permission in writing from Glen Dimplex



For electrical products sold within the European Community. At the end of the electrical products useful life it should not be disposed of with household waste. Please recycle where facilities exist. Check with a Local Authority or retailer for recycling advice in your country. Batteries should be disposed of or recycled in accordance with WEEE Directive 2012/EU. Packaging should be recycled where possible.

