

© Product installation and operation guide



TIME DELAY RESIDUAL CURRENT DEVICES



LIVE ELECTRICAL DISTRIBUTION UK LTD

4 Queensmead Place, Textilose Road, Manchester, M17 1PH
Tel: 0161 8702592 Web: www.liveelectrical.co.uk
E-mail: sales@liveelectrical.co.uk



Ensure that these instructions are made available to the end user for future reference.

TIME DELAY RESIDUAL CURRENT DEVICES

Construction and Feature

Provides protection against earth fault/leakage current and function of isolation; High breaking current withstand capacity; Applicable to terminal and pin type busbar connection; Equipped with finger protected connection terminals; Flame resistant plastic parts endures abnormal heating and strong impact; Automatically disconnect the circuit when earth fault/leakage current occurs and exceeds the rated sensitivity; Independent of power supply and line voltage, and free from external interference, voltage fluctuation.

Technical Data

- Pole No.: 2.
- Rated current(A):80 100A.
- Rated voltage: 240/415V AC.
- Rated frequency: 50/60Hz.
- Rated residual operating current $I_{\Delta}(\text{mA})$:30,100.
- Rated residual non operating current: $0.5I_{\Delta n}$.
- Rated conditional breaking current Inc: 6000A.
- Tripping duration Instantaneous tripping $\leq 0.1\text{s}$.
- Residual tripping current range: $0.5I_{\Delta n}\sim I_{\Delta n}$.
- Electro-mechanical endurance:4000 cycles.
- Connection capacity Rigid conductor up to 35mm^2 .
- Connection terminal Screw terminal.
- Pillar terminal with clamp.
- Fastening torque 2.0 Nm.
- Installation: On symmetrical DIN rail 35mm.
- Panel mounting.

Part No	Description	Box Qty
RT280-100	2Pole 80Amps 100mA Type AC Time Delay RCD	60
RT2100-100	2Pole 100Amps 100mA Type AC Time Delay RCD	60
RTA280-100	2Pole 80Amps 100mA Type A Time Delay RCD	60
RTA2100-100	2Pole 100Amps 100mA Type A Time Delay RCD	60

Wiring Diagram

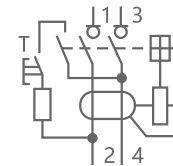

Product Dimension

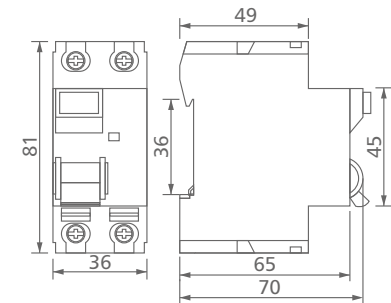

Safety Instructions -Important

- 1.Before using RCD, it is first necessary to ensure that the circuit is powered off and the RCD is correctly installed in the circuit. RCD is usually installed upstream of the circuit.
- 2.Next, connect the circuit correctly to the associated MCB output terminal. The input terminal of the circuit should be connected to the busbar, while the output terminal of the circuit should be connected to the electrical equipment that needs protection. The neutral cable for the circuit shall be connected to the neutral bar.

3. After connecting the circuit, it is necessary to test the RCD to ensure its normal operation. The method for testing RCD is as follows:

3.1 Press the test button on the RCD and observe if the RCD immediately cuts off the circuit. If the RCD operates normally, the circuit will immediately disconnect.

3.2 If the RCD does not cut off the circuit, it may be due to a malfunction or incorrect connection of the RCD itself. At this point, the wiring and circuit connections of the RCD should be checked to ensure correctness.

3.3 If the RCD still does not function properly after inspection, it is recommended to replace it with a new RCD.

4. After the RCD is functioning properly, the circuit can be energised. When using RCD, the following points need to be noted:

4.1 Before each use of electrical equipment, check whether the RCD is working properly. You can press the test button for testing to ensure that the RCD can cut off the circuit in a timely manner.

4.2 If the RCD cuts off the circuit, it may be due to a malfunction in the electrical equipment or leakage in the circuit. At this point, troubleshoot or repair the circuit, and ensure that the problem is resolved before retesting the RCD. 3. Regularly check the working status of RCD to ensure its normal operation. It is recommended to test the RCD every three months, and if any abnormalities are found, a new RCD should be replaced in a timely manner.

Note:

When using RCD, the following points should also be noted:

1. RCD can only be used in AC circuits and cannot be used in DC circuits.

2. RCD can only protect personal safety and cannot protect the equipment itself. Therefore, when using electrical equipment, it is still necessary to pay attention to the normal working state of the equipment.

Tips:

Waste electrical products should not be disposed of with household waste. Please recycle where waste disposal facilities exist.

Check with your retailer, wholesaler or local authority for recycling advice.